

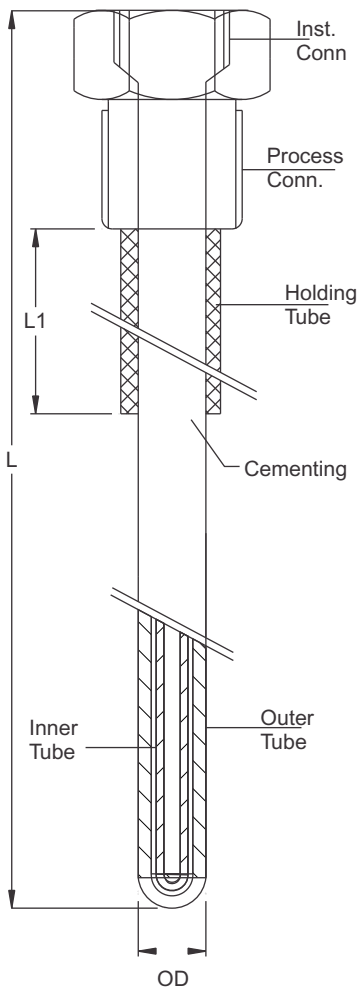

# THERMOWELL WITH CERAMIC TUBE

## TEC-113



**Inner Tube Material**

**Inner Tube OD (mm)**

**ID (mm)**

**Outer Tube Material**

**Outer Tube OD (mm)**

**ID (mm)**

**Holding Tube Material**

**Holding Tube OD (mm)**

**ID (mm)**

**Length "L1" (mm)**

**Process Conn.**

**Instrument Conn.**

**Total Length "L"**

|     |  |
|-----|--|
| 304 | SS 304                                   |
| 310 | SS 310                                   |
| 316 | SS 316                                   |
| 600 | Inconel-600                              |
| 800 | Inconel-800                              |
| 446 | HRS- 446                                 |
| 610 | Recrystallised Alumina Ceramic- Ker- 610 |
| 710 | Recrystallised Alumina Ceramic- Ker- 710 |

|     |             |
|-----|-------------|
| 304 | SS 304      |
| 310 | SS 310      |
| 316 | SS 316      |
| 600 | Inconel-600 |
| 800 | Inconel-800 |
| 446 | HRS- 446    |

|                  |                           |
|------------------|---------------------------|
| Threads          | 1/4"                      |
|                  | 1/2"                      |
|                  | 3/4"                      |
|                  | 3/8"                      |
|                  | 1"                        |
|                  | 1 1/4"                    |
| B.S.P/<br>N.P.T. | 1 1/2"                    |
|                  | 2"                        |
|                  | M-Thread                  |
| M-Thread         | M20X1.5, M18X1.5<br>M27X2 |
| Other            | Consult Factory           |

C