

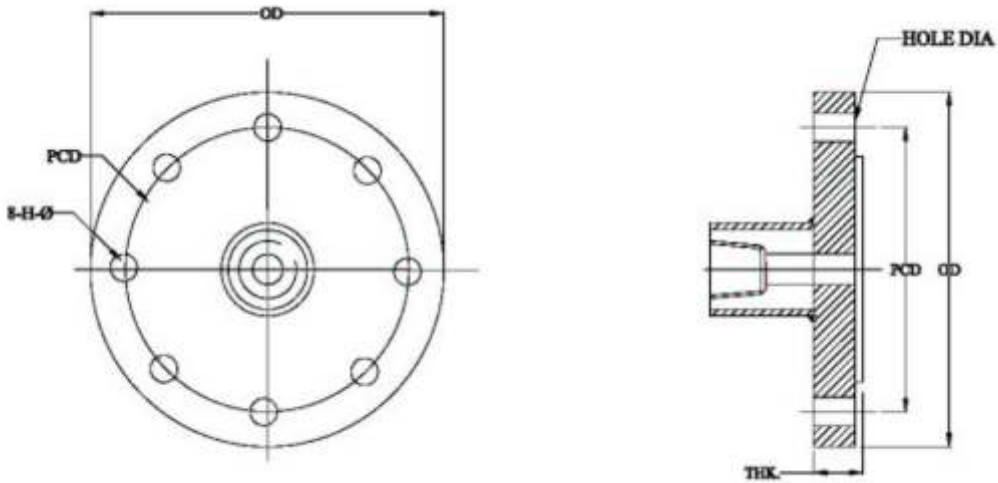

SOCKET WELD FLANGE



SIZE	Rt/sq.in	O.D.	PCD	NO. OF HOLE	HOLE DIA	THK.	RF	RFT
1/2" (15 NB)	150	88.9	60.5	4	15.7	11.2	35.1	1.6
3/4" (20 NB)	150	98.6	69.9	4	15.7	12.7	42.9	1.6
1.0" (25NB)	150	108.0	79.2	4	15.7	14.2	50.8	1.6
1-1/4" (32NB)	150	112.3	88.9	4	15.7	15.2	63.5	1.6
1-1/2" (40 NB)	150	127.0	98.6	4	15.7	17.5	73.2	1.6
2" (50 NB)	150	152.4	120.7	4	19.1	19.6	91.9	1.6
2-1/2" (65NB)	150	177.8	139.7	4	19.1	22.4	104.6	1.6
3.0" (80NB)	150	190.5	152.4	4	19.1	23.9	127.0	1.6
1/2" (15 NB)	300	95.2	60.9	4	15.7	14.2	35.0	1.6
3/4" (20 NB)	300	117.3	82.6	4	19.1	15.9	42.9	1.6
1.0" (25NB)	300	124.0	88.9	4	19.1	17.5	50.8	1.6
1-1/4" (32NB)	300	133.3	98.6	4	19.1	19	63.5	1.6
1-1/2" (40 NB)	300	155.4	114.0	4	22.3	20.6	73.2	1.6
2" (50 NB)	300	165.1	127.0	8	22.3	22.3	92	1.6
2-1/2" (65NB)	300	190.5	149.4	8	22.3	25.4	104.6	1.6
3.0" (80NB)	300	209.6	168.4	8	22.3	28.4	127.0	1.6



1/2" (15 NB)	400/600	95.2	66.5	4	15.7	20.6	35.0	6.4
3/4" (20 NB)	400/600	117.3	82.6	4	19.1	22.0	42.9	6.4
1.0" (25NB)	400/600	124.0	88.9	4	19.1	23.4	50.8	6.4
1-1/4" (32NB)	400/600	133.3	98.6	4	19.1	27.0	63.5	6.4
1-1/2" (40 NB)	400/600	155.4	114.3	4	22.4	28.8	73.2	6.4
2" (50 NB)	400/600	165.1	127.0	8	19.1	30.8	91.9	6.4
2-1/2" (65NB)	400/600	190.5	149.4	8	22.4	34.8	104.0	6.4
3.0" (80NB)	400/600	209.6	168.1	8	22.4	38.8	122.0	6.4