

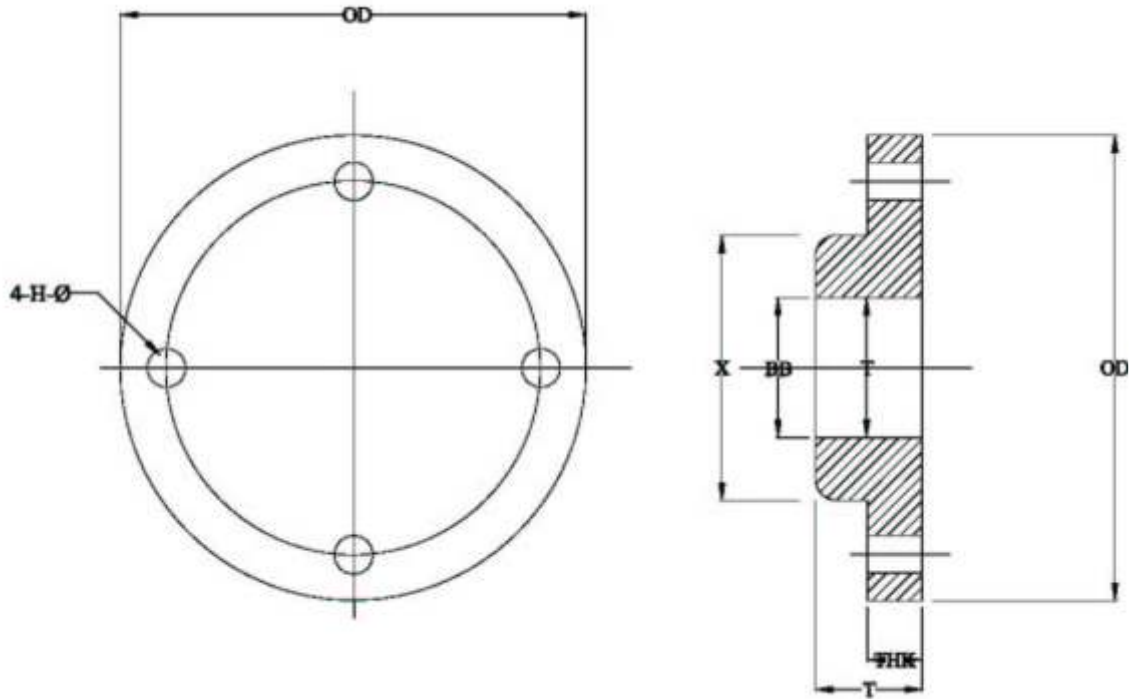

LAP JOINT FLANGE



Nom. Pipe Size (inches)	OD	THK.	Lb/Sq.in	X	No. and** Dia. of Bolt Holes	Bolt Circle Dia	T	BB
1/2	3.50	.44	150	1.19	4 -0.62	2.38	1.88	.90
3/4	3.88	.50	150	1.50	4 -0.62	2.75	2.06	1.11
1	4.25	.56	150	1.94	4 -0.62	3.12	2.19	1.38
1 1/4	4.62	.62	150	2.31	4 -0.62	3.50	2.25	1.72
1 1/2	5.00	.68	150	2.56	4 -0.62	3.88	2.44	1.97
2	6.00	.75	150	3.06	4 -0.75	4.75	2.50	2.46
2 1/2	7.00	.88	150	3.56	4 -0.75	5.50	2.75	2.97
3	7.50	.94	150	4.25	4 -0.75	6.00	2.75	3.60



1/2	3.75	0.56	300	1.38	1.50	4-0.62	2.62	2.06	0.90
3/4	4.62	0.62	300	1.69	1.88	4-0.75	3.25	2.25	1.11
1	4.88	0.69	300	2.00	2.12	4-0.75	3.50	2.44	1.38
1 1/4	5.25	0.75	300	2.50	2.50	4-0.75	3.88	2.56	1.72
1 1/2	6.12	0.81	300	2.88	2.75	4-0.88	4.50	2.69	1.97
2	6.50	0.88	300	3.62	3.31	8-0.75	5.00	2.75	2.46
2 1/2	7.50	1.00	300	4.12	3.94	8-0.88	5.88	3.00	2.97
3	8.25	1.12	300	5.00	4.62	8-0.88	6.62	3.12	3.60
1/2	3.75	0.56	400 / 600	1.38	1.50	4-0.62	2.62	2.06	0.90
3/4	4.62	0.62	400 / 600	1.69	1.88	4-0.75	3.25	2.25	1.11
1	4.88	0.69	400 / 600	2.00	2.12	4-0.75	3.50	2.44	1.38
1 1/4	5.25	0.81	400 / 600	2.50	2.50	4-0.75	3.88	2.62	1.72
1 1/2	6.12	0.88	400 / 600	2.88	2.75	4-0.88	4.50	2.75	1.97
2	6.50	1.00	400 / 600	3.62	3.31	8-0.75	5.00	2.88	2.46
2 1/2	7.50	1.12	400 / 600	4.12	3.94	8-0.88	5.88	3.12	2.97
3	8.25	1.25	400 / 600	5.00	4.62	8-0.88	6.62	3.25	3.60
1/2	4.75	0.88	900 / 1500	1.38	1.50	4-0.88	3.25	2.38	0.90
3/4	5.12	1.00	900 / 1500	1.69	1.75	4-0.88	3.50	2.75	1.11
1	5.88	1.12	900 / 1500	2.00	2.06	4-1.00	4.00	2.88	1.38
1 1/4	6.25	1.12	900 / 1500	2.50	2.50	4-1.00	4.38	2.88	1.72
1 1/2	7.00	1.25	900 / 1500	2.88	2.75	4-1.12	4.88	3.25	1.97
2	8.50	1.50	900 / 1500	3.62	4.12	8-1.00	6.50	4.00	2.46
2 1/2	9.62	1.62	900 / 1500	4.12	4.88	8-1.12	7.50	4.12	2.97
3	9.50	1.50	900 / 1500	5.00	5.00	8-1.00	7.50	4.00	3.60
1/2	5.25	1.19	2500	1.38	1.69	4-0.88	3.50	2.88	0.93
3/4	5.50	1.25	2500	1.69	2.00	4-0.88	3.75	3.12	1.14
1	6.25	1.38	2500	2.00	2.25	4-1.00	4.25	3.50	1.41
1 1/4	7.25	1.50	2500	2.50	2.88	4-1.12	5.12	3.75	1.75
1 1/2	8.00	1.75	2500	2.88	3.12	4-1.25	5.75	4.38	1.99
2	9.25	2.00	2500	3.62	3.75	8-1.12	6.75	5.00	2.50
2 1/2	10.50	2.25	2500	4.12	4.50	8-1.25	7.75	5.62	3.00
3	12.00	2.62	2500	5.00	5.25	8-1.38	9.00	6.62	3.63